

Conceptual design of a compact optical synthetic aperture telescope

Neng-hong Zhu¹, Xin-yang Chen¹, Dan Zhou¹, Cong-cong Zhang¹,
Li-xin Zheng¹, Chao-yan Wang¹

¹*Shanghai Astronomical Observatory, 200030, Shanghai, China*

Abstract. Y-4 synthetic aperture telescope consists of four 40cm sub-telescopes that are configured as Y-type array based on an unique AZ-Alt mounting. After passing through every sub-aperture, star lights are transformed into parallel beams, enter relay optics for co-phasing sensing, finally combined by an optical combiner and form interferometric images in image plane. Because all tubes are installed on single mounting, the complicate outer optical delay line can be avoided. Y-4 array telescope is of some advantages such as efficient diameter, angle resolution with respect to some other configurations. Some negative influence of beam combining errors including piston, tip/tilt, and pupil mapping error aiming to Y-4 array is analyzed subsequently. The preliminary mechanical and optics design of Y-4 telescope is introduced respectively.

1. Introduction

High sensitivity and resolution are two foremost motivations for building optical telescopes since several centuries all along. These specifications are associated with aperture of telescopes, performance of terminals and atmospheric turbulence closely. To enlarge telescope aperture is a general valid method for scientists. A few of giant optical telescopes projects with 30-40 meters diameter and 2-5 thousands of tons weight are ongoing at present. Unfortunately, so large-scale size and heavy weight will bring overwhelming technological challenges to optics, mechanics and control design and manufacture of giant telescopes. Optical interferometer which is thought as a technique can break through aperture limit is developing subsequently. Two or more than two small telescopes are arranged as an array, and multiple beams are combined to achieve interferometric image with high angular resolution which is proportional with length of baselines (separation between sub-telescopes).

There are two fundamental beam-combining way of interferometry. Michelson interferometry is also called pupil-plane interferometry combines multiple beams from independent light collectors with long baselines (up to several hundred meters) by co-axial way and feeds superimposed beams to detector to obtain interfered fringe. At each baseline orientation, only single spatial frequency point is measured, and the u-v plane must be filled in by adding many non-redundant baselines and rotating baselines over a long period of time (e.g. earth rotation).

Fizeau interferometry which is also called image-plane interferometry has compact telescope arrays and multiple beams are focused to image plane with much shorter baselines by a multi-axial beam combiner. Fizeau interferometers produce direct images with nearly full instant u-v plane coverage by mounting tracking. If amount of sub-apertures is above 3, this interferometer also would be named by synthetic aperture telescope.

A new conception of Y-4 Fizeau synthetic aperture telescope will be introduced in the next chapters. This telescope is composed of four 40cm sub-telescopes that are configured as Y-type array based on an unique Alt-AZ mounting. After passing through every sub-telescope, star lights are transformed into parallel beams, enter relay optics for co-phasing sensing, finally combined by an optical combiner and form interferometric images in image plane. Because all tubes are installed on a single mounting, the complicate outer optical delay line can be avoided. But some high precision sensing and compensation set-up for inner optical path errors induced by manufacturing, installing, gravity, thermal etc. is necessary.

Chapter 2 describes some advantages of Y-4 array according to the characteristics of PSF distribution and u-v plane coverage in contrast to some other array configurations. Chapter 3 analyzes some negative influences of beam combining errors including piston, tip/tilt, and pupil mapping error aiming to Y-4 array. Chapter 4 and Chapter 5 introduce preliminary mechanical and optics design of Y-4 telescope respectively.

2. Array configuration

An interferometric intensity formula aiming to an array of multiple apertures is given (Mennesson & Mariotti 1997) .

$$I \propto \left| \frac{\pi D (1 + \cos r)^2}{\lambda} \right|^2 \left| \frac{J_1(\pi D \sin r / \lambda)}{\pi D \sin r / \lambda} \right|^2 \left| \sum_{k=1}^n e^{j2\pi(\frac{L_k r}{\lambda})(\delta_k - \theta)} e^{j\varphi_k} \right|^2 \quad (1)$$

D is the diameter of sub-aperture, and J_1 is the 1st order Bessel function of the first kind. (L_k, δ_k) is the polar coordinate of each sub-aperture center. A point source is located at angular separation r from reference center. θ is the azimuth angle which spread from 0 to 2π , and φ_k is the phase shift given to each beam before entering the beam combiner. The first item of Equation (1) is constant over a small range of r. The second item is the intensity pattern of a single aperture and the third item is an array interference factor.

In general, imaging quality can be evaluated on the basis of point spread function (PSF). PSF of multiple aperture array obviously depend upon the number of sub-telescopes, the apertures diameter, the length of interferometer arm, and the topological structure of array according to Equation (1). Considering the feasibility of opto-mechanical design and to keep a compact structure as far as possible, we primarily determine the equivalent diameter of synthetic aperture array is about 1m, the diameter of sub-aperture is 40cm, and the amounts is 3 or 4. Fig.1-a, 1-b, 1-c show several optimal symmetrical arrays configuration: square array, Y-3 array and Y-4 array. Some main configuration variables of different arrays are listed in Table 1. Fig.1-d, 1-e and 1-f are simplified sketches of Modulation Transfer Function (MTF) of arrays so called u-v plane coverage.

MTF is used to evaluate the characteristic of transferring intensity contrast for telescopes in spatial frequency domain (Chung 2002) and determine synthetic aperture telescopes angular resolution in practice. Dashed circles indicate special frequency regions realized by each kind of array. A solid circle edge means the cut-off frequency of MTF in which there is no loss of frequency. The radius of solid circle is equivalent to the instantaneous effective diameter of array D_e . The larger is D_e , the higher is angular resolution. The D_e of Y-4 array is maximum for these three array configuration. MTF of multiple aperture array is unsymmetrical in frequency domain. Fig.2 is the distribution of MTF along with different orientation angle: 10° and 20° . The MTF within low frequency band of the square array and Y-4 array is obviously higher than Y-3 array. At the meanwhile, the cut-off special frequency of Y-4 array is higher than square array. The Y-4 array is an optimal configuration.

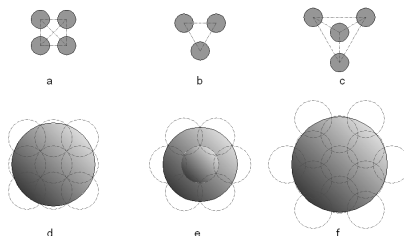

Figure 1.: Graph of array configuration and u - v coverage.

Table 1.: Parameters of different array configuration.

Variables	Square array	Y-3 array	Y-4 array
Number of sub-apertures	4	3	4
Number of baselines	6	3	6
Length of baselines	565/799mm	690mm	650/1126mm
Effective diameter	894mm	800mm	1028mm

3. Beam combining errors and total errors budget

For a optical aperture synthesis telescope, its imaging quality will mainly suffer from beam combining errors including piston, tip/tilt and pupil mapping error. As the piston error increases, several major deviations will develop over the envelope of the PSF distribution. Firstly, the main envelope shifts in the direction of the piston error. Secondly, the peak intensity gets reduced compared to the normal PSF without any piston errors resulting in a reduced Strehl Ratio (SR). The size of the main lobe also expands showing a degraded angular resolution. The piston error tolerance should less than 0.1λ if should SR be above 90%.

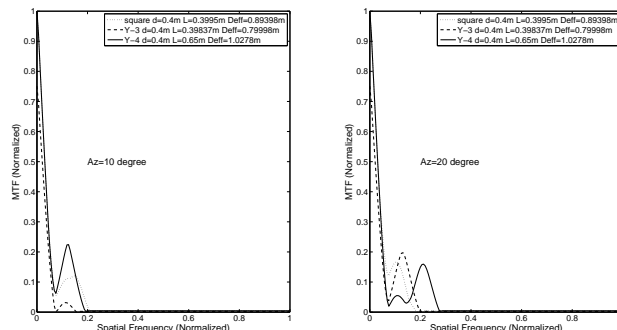

Figure 2.: *MTF of different array configuration.*

Tip/tilt error is usually classified by X axis tip error and Y axis tilt error. The energy of main lobe of PSF distribution will spread to other side lobe as tip/tilt error increases. The response of MTF between low and middle spacial frequency domain will also decline . It also means the imaging quality will degenerate rapidly. For polychromatic light, supposed SR reaches 90%, the tip/tilt error tolerance should be less than 0.3 arcsecond. Pupil mapping errors mainly include shear error and magnification error. In this paper it specially refer to shear error which comes from the incorrect sub-aperture image locations across the beam combiners entrance pupil plane. For a certain Field-of-View(FOV), SR will decrease gradually with pupil mapping error increasing. In particular, the variety of SR following with pupil mapping error is also distinguishing with respect to different FOV. Larger is the FOV, quicker is the decreasing velocity of SR as pupil mapping error increases. It is obvious that pupil mapping error should be limited in order to satisfy a certain FOV and SR. According to our simulation, the pupil mapping error tolerance of Y-4 array telescope should be limited to 0.015λ .

Errors analysis is an important design method aiming to all components bring errors to system performance. Each error tolerance strictly defines the rms error which can be introduced during each step of the design, manufacture, assembly and operations. Figure 3 is a total errors budget of Y-4 array telescope (Cao & Wu 2009).

4. Mechanism design

Fizeau synthesis aperture telescope is of some mechanical characteristics which are different from classical single aperture telescopes.

(1) Coincidence of tubes fabrication and installation is very strict because of ensuring multiple aperture good co-phasing.

(2) There is a suit of collimation and folding light-path between each telescope main optics and beam combiner. Because these four set of light-path set-up are used to measure and compensate piston and tip/tilt error, the mouting must have higher rigidness and anti-vibration.

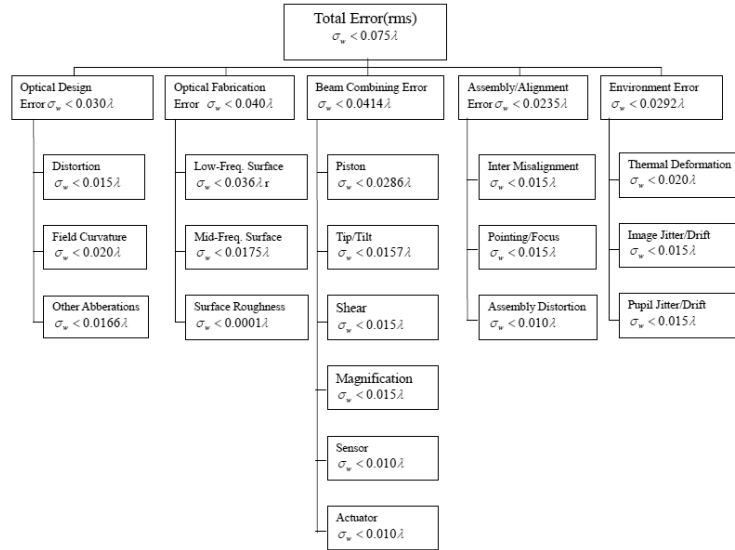

Figure 3.: Total errors budget of Y-4 array.

(3) The mounting distortion induced by environment variables such as temperature and wind loads.

On the basis of referring to mechanism design scheme of Large Binocular Telescope(LBT), we also apply C-shape board concept to mechanical structure of Y-4 synthesis aperture telescope. Four sub-telescopes are installed on the a triangle platform which is fixed with two C-shape boards. All collimation and folding light-path set-up are placed on the platform,while the beam combiner is below. The two boards are linked through trusses firmly. Figure 4 is a structure model of Y-4 synthesis aperture telescope.

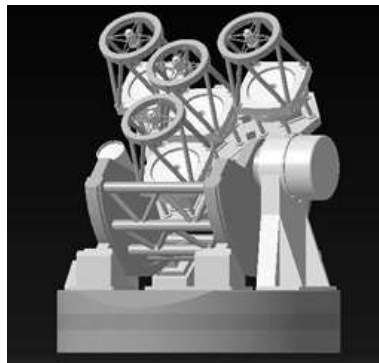

Figure 4.: Structure model of Y-4 synthesis aperture telescope.

This scheme shows several significant advantages relative to conventional AZ-ALT tracking mounting of telescopes. Firstly, a whole triangle platform replacing traditional middle block component will enforce rigidity of structure and heighten resonance frequency of mechanical system. Secondly, all sub-telescopes, collimation and folding set-up can be modularized by batch fabrication thanks to same opto-mechanism. So each module can be assembled and adjusted individually on the laboratory. This point is very useful to reducing assembly errors and difficulties on site. Finally, the mounting structure is open entirely, and therefore is good for thermal balance of the whole environment.

4.1 Mounting

The tracking mounting consists of the triangle platform and C-shape boards and each other are linked through trusses made of profiled steel. The total mass of mounting is about 3961Kg. We give a certain gravitational acceleration to the whole module and tube payload to the link section. The peak distortion of mounting is about $5.92 \mu\text{m}$. And the finite element modal analysis shows that the minimum resonance frequency is 130.49Hz. In general, the above results confirm this mounting structure is of significant advantage in mechanics.

4.2 Sub-telescope tube

The sub-telescope tubes will be supported by trusses which is made of SiC, while the rest part is made of steel. The total mass of each suit of tube is up to 157Kg. The peak distortion of tube is about $7.24 \mu\text{m}$. and the minimum resonance frequency of tube is 122.82Hz.

5. Optics design

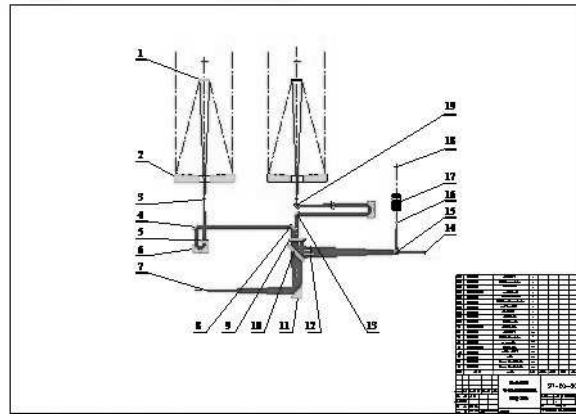

Figure 5.: *Optical layout of Y-4 optical synthesis aperture telescope.*

Figure 5 shows the optical layout of Y-4 optical synthesis aperture telescope. This optical system consists of four sub-telescopes, four collimation & folding optical path set-up, beam combiner and imaging terminal. Incident light will

pass through each sub-telescope with 400 mm diameter and collimator lens, and will produce collimated beams with 20 mm diameter. After reflecting by some folding mirrors, then these beams reach to beam combiner together. Finally, form a multiple-axis image at the focus of combiner.

We hope the focal ratio of primary mirror is as short as possible considering cost, optical stability and tracking accuracy. We chose Ritch-Chretien optical structure as main optics of the sub-telescope. The primary mirror of each sub-telescope is of a concave hyperboloidal surface and the secondary mirror is convex hyperboloidal. They are both made of ceramics glass. Thanks to this system can eliminates spherical and comet aberrations well, the diameter of confusion circle is less than 0.7 ''.

Folding light path consists of field lens and some 45 ° folding mirrors. A double separate objective lens is applied to beam combining. In order to satisfy the Homothetic Rule of optical synthesis aperture telescope, we determine the diameter of beam combiner is 85 mm at least.

6. Conclusions

We introduce a conceptual design scheme of Fizeau optical synthesis aperture telescope which consists of 4 sub-telescopes including array configuration, error budget, mechanism and optics design. This kind of compact structure maybe suit for spacial optical interferometer project in future.

References

- Mennesson, B., & Mariotti, J.M. 1997, ICARUS, 128, 202
Soon-Jo Chung. 2002, Design, Implementation and control of a sparse aperture imaging satellite:[D].,
Cao F., Wu Z. 2009, in Fizeau interferometer Conf., Internal report ed. Neng-hong Zhu, 115