

The Polarization-Based Solution for Dual-Star Interferometry for Precise Astrometry

Jeff Meisner

Leiden Observatory & Technical University of Delft

- This is an initial proposition (unlike my previous talk) describing an alternative topology to implement dual-field interferometry for off-axis phase-referencing and narrow-angle astrometry.
- Proposal being presented for the first time, not yet published, and feedback from the interferometry community (you!) is sought and highly appreciated! (Be the first to point out a fatal flaw :-)
- Particular attention is sought from ESO and those among the ESO community involved with the PRIMA astrometric mode.
- However this proposal is *not* advanced as a redesign of PRIMA, and should not be construed as a response to some particular shortcoming of PRIMA. It may be developed by ESO in parallel with PRIMA, in which case we can learn from comparison of their results in view of the systems' similarities and differences.
- It is also proposed as an add-on to *any* existing interferometer in to obtain dual-beam capability without a major overhaul of the infrastructure.

Purpose:

- Send light from two stars/fields to the interferometric laboratory
- Know and control the OPD offset τ_A between the A star paths to its beamcombiner and τ_B applying to the B star paths going to its beamcombiner
- Fringe track on the brighter star (A) controlling τ_A while applying the same OPD fluctuations (reflecting the fluctuating atmosphere) to τ_B with a specified and known offset

$$\Delta\tau = \tau_B - \tau_A$$

- Now the fringe signal of star B is stabilized and its light can be integrated coherently even if very faint, resulting in an estimate of the complex visibility V_B relative to the position of the A star offset by $\Delta\tau$, which can be used for image reconstruction, or for precision narrow-angle astrometry as long as $\Delta\tau$ is accurately known.
- The “dual star facility” accomplishes this beam transport and control/knowledge of the two stars' OPD offset $\Delta\tau$.

Comparison of the interferometric infrastructures used in PRIMA (and the similar systems at KI etc.) and the proposed polarization-multiplexed solution used for the same purpose

PRIMA (etc.)

- Starlight from A and B stars are *separated* at each telescope before being sent down the beam paths
- *Two* separate adjacent beam paths are used for the stars, up to the their respective beam combiners
- A differential delay line (DDL) somewhere in the beam paths introduces the intended $\Delta\tau$ offset.
- Knowledge of $\Delta\tau$ is obtained through end-to-end metrology, from a point (virtually) outside the telescopes to each beamcombiner

Polarization multiplexed proposal

- Starlight from A and B stars are *superimposed* in the same spatial mode (but opposite polarizations) before being sent down the beam path.
- Only *one* beam path is used for both stars, up to the beam combiner assembly
- A differential delay line (DDL) inside the beam combiner assembly introduces the intended $\Delta\tau$ offset.
- $\Delta\tau$ is directly measured inside the beam combiner assembly only, with the paths from the telescope being fixed and almost identical (or at least calibratable).

Standard dual-star system as used in PRIMA, also at PTI and KI.

Referencing of path lengths dependent on end-to-end laser metrology encompassing entire optical paths to reference points outside the star separator between which the baseline is defined

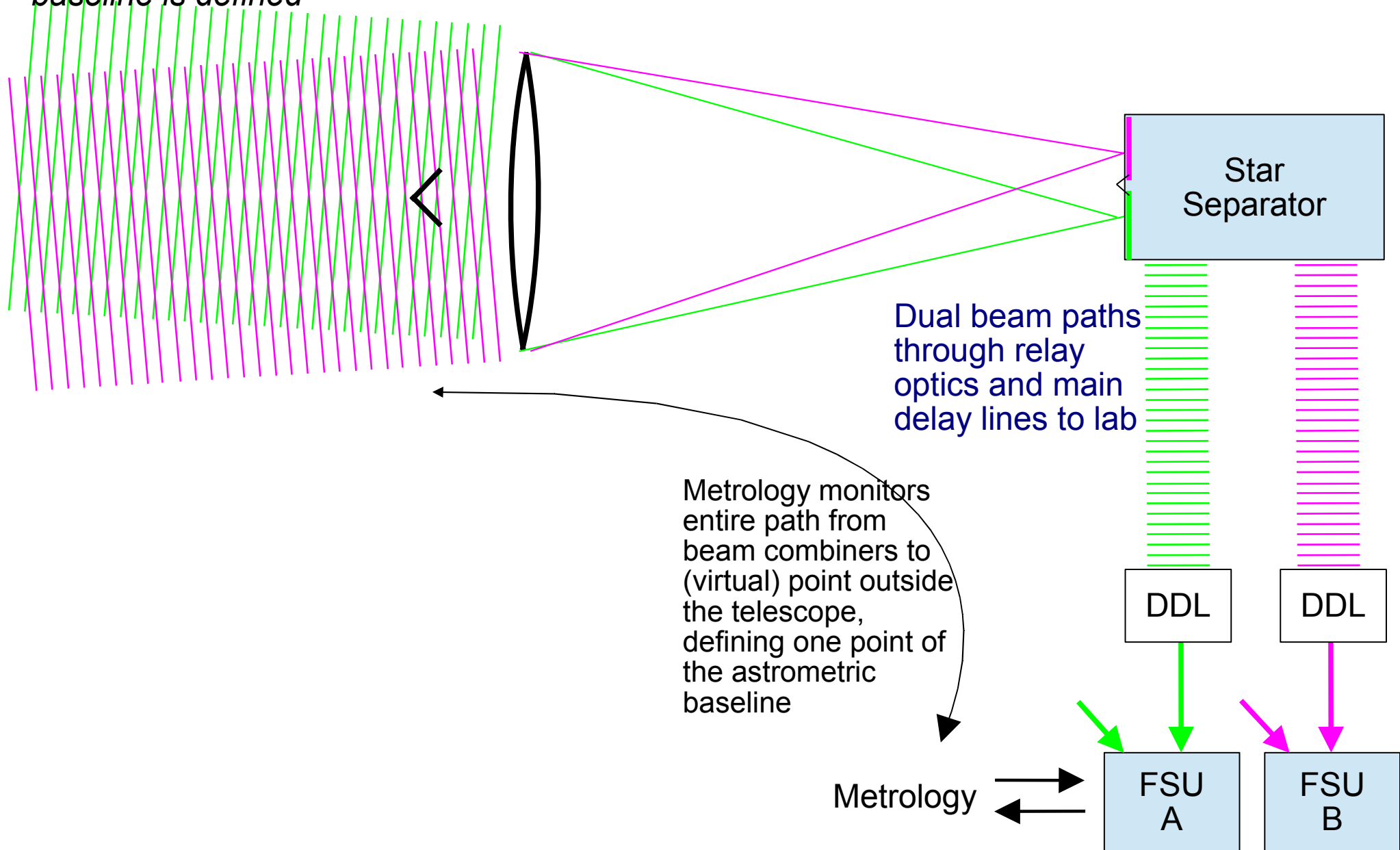

Polarization (or wavelength) multiplexing solution considered early in design of PRIMA (but rejected)

However:

- Still contained a star separator after which the two beams were recombined (in separate polarizations)
- Still required a precision metrology system (albeit over a much shorter path) in order to monitor the non-common-mode path, up to a point before the star separator
- **Sacrifices 1/2 of the starlight (as does the current proposal) by using only one polarization from each star**

Main advantages:

- Eliminates need for twice as many long optical paths from telescopes and in delay lines
- Alleviates concern with metrology errors over a long path due to air dispersion between stellar and metrology wavelengths.

PRIMA -- Study for a Dual-Beam Instrument for the VLT Interferometer,
A. Quirrenbach et. al, 1998

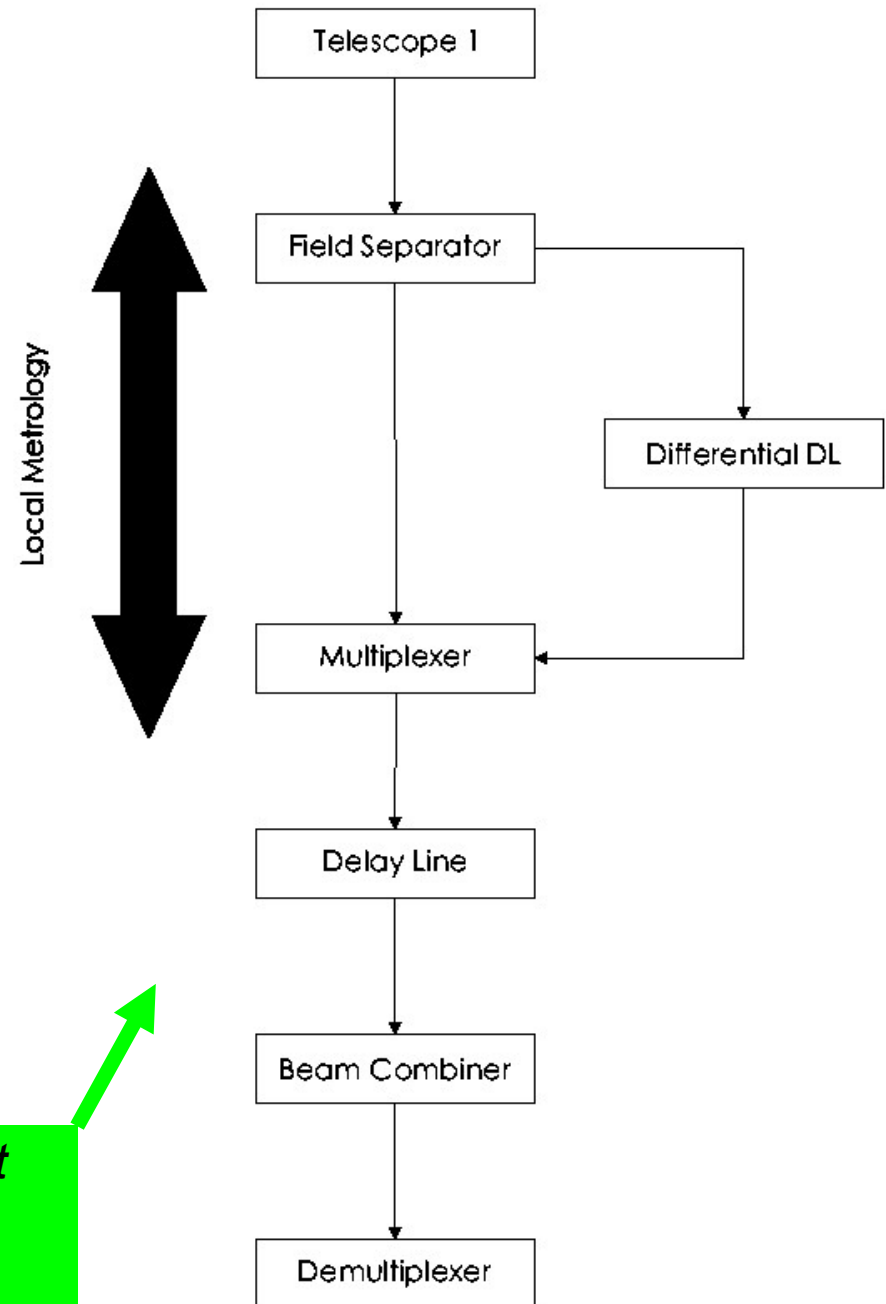

The proposed polarization-multiplexed system

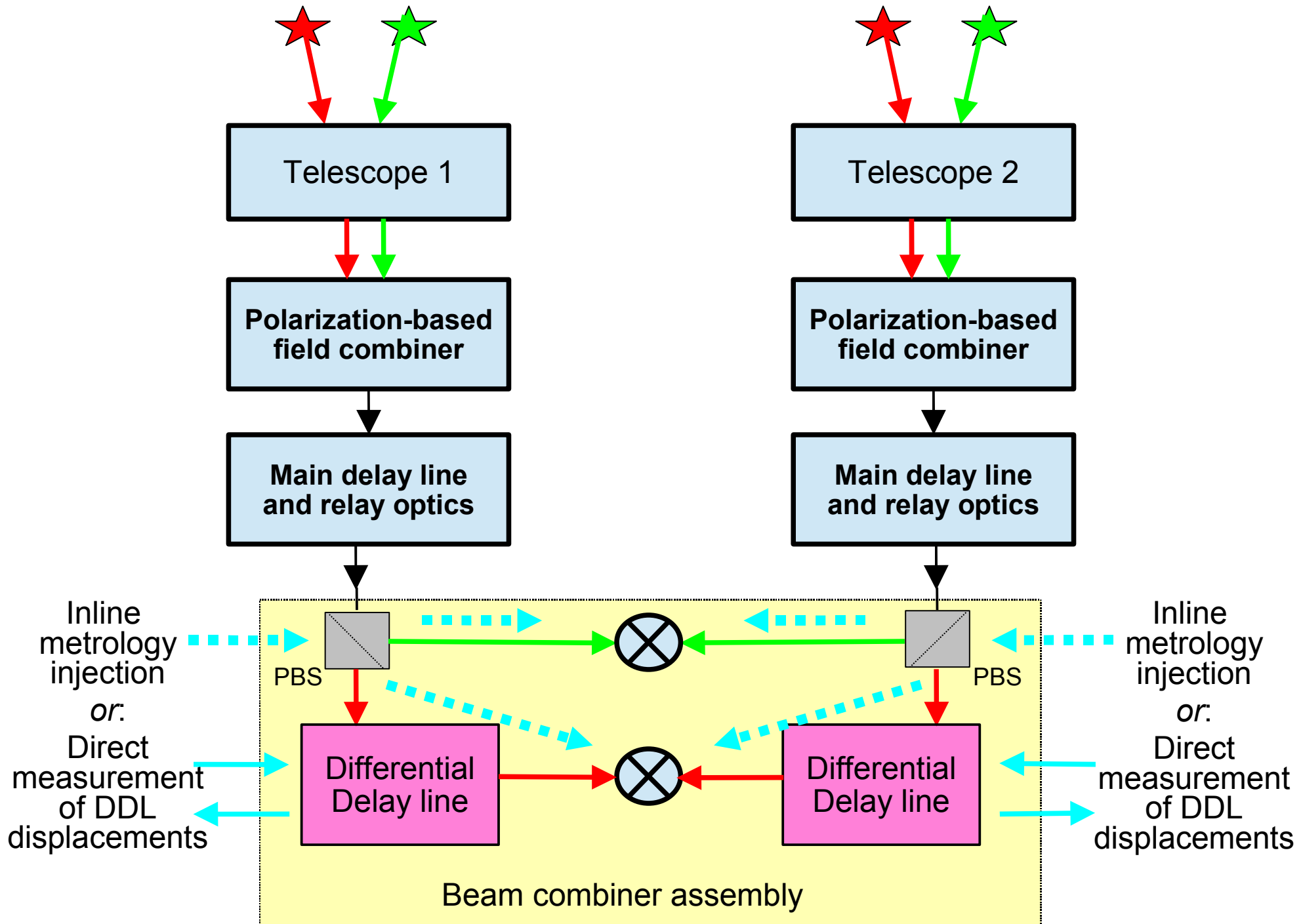

Features of the proposed system

- No separation of light from A and B stars at any point, no separate optics
- The two waves, after being tilted into the same direction, remain in the same spatial mode (but opposite polarization) up until splitting at the instrument
- Detection of zero-OPD point through injection of one star into both paths (both polarizations) achieved without change in observing geometry and without breaking lock on primary star.
- Other beam commutation methods available, some involving no change in observing geometry.
- Stability of OPD referencing based on non-birefringence of air (in propagating paths) and non-variability of birefringence in folding mirrors in paths following polarization field combination.
- Metrology of variable differential path (DDL's) occurs over short path inside instrument under controlled environmental conditions.
- Relative hardware simplicity compared to system with star separators, dual beam delay lines and relay optics, and metrology system encompassing all that.

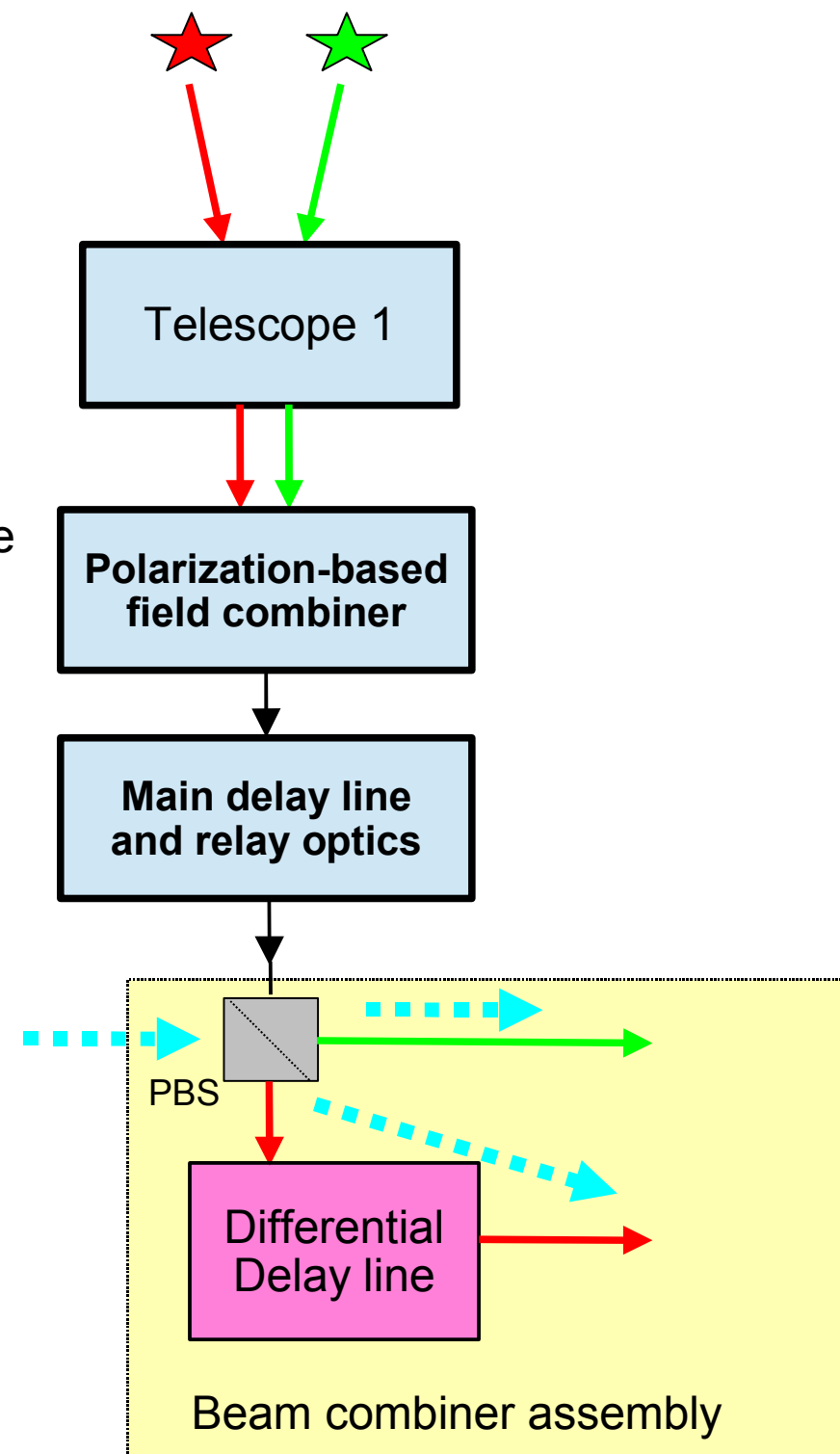

Most novel element of the proposed system:
The Polarization-based field combiner

Imagine a huge Wollaston prism placed at the objective of a telescope. The light of a star is separated by polarization, producing two images at the focus:

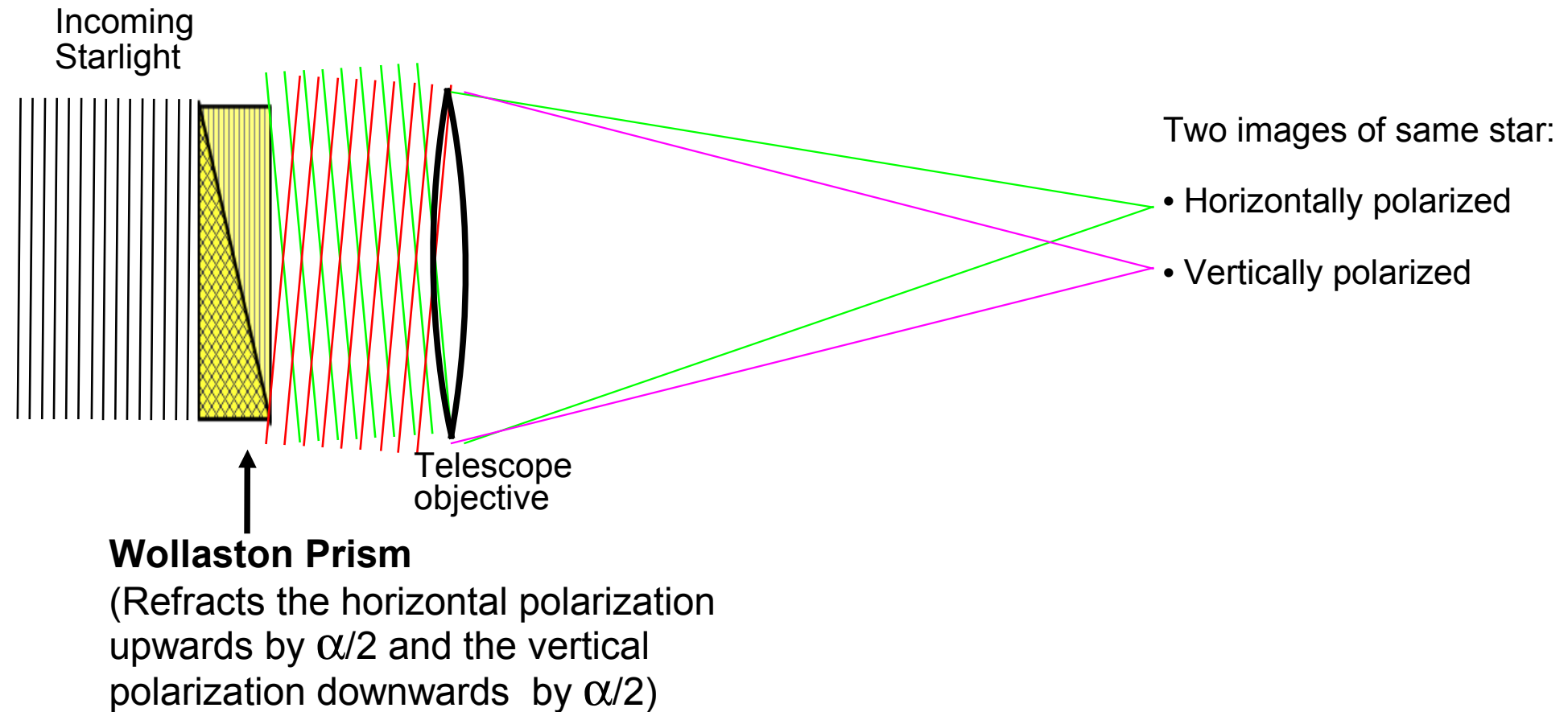

With 2 stars separated by α , each star produces two images, one for each polarization. The vertically polarized image of star B and the horizontally polarized image of star A are now superimposed!

Star A

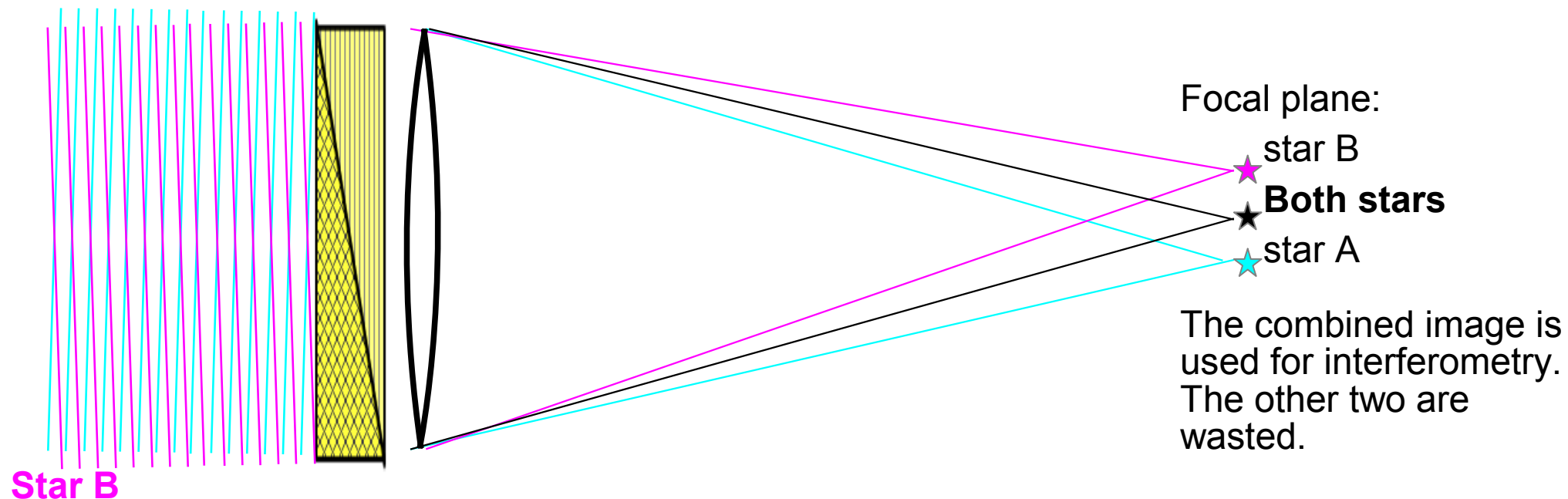

Of course the configuration shown is extremely impractical:

- Such a large Wollaston prism could never be produced!
- This would only work for two stars which are separated by exactly α ; stars with any other separation wouldn't produce overlapping images.

Solution to use a Wollaston prism N times smaller (but with N times the refractive power α):

Build an afocal telescope with a magnification of N , followed by the previously described system N times smaller (but observing an astrometric separation apparently N times larger):

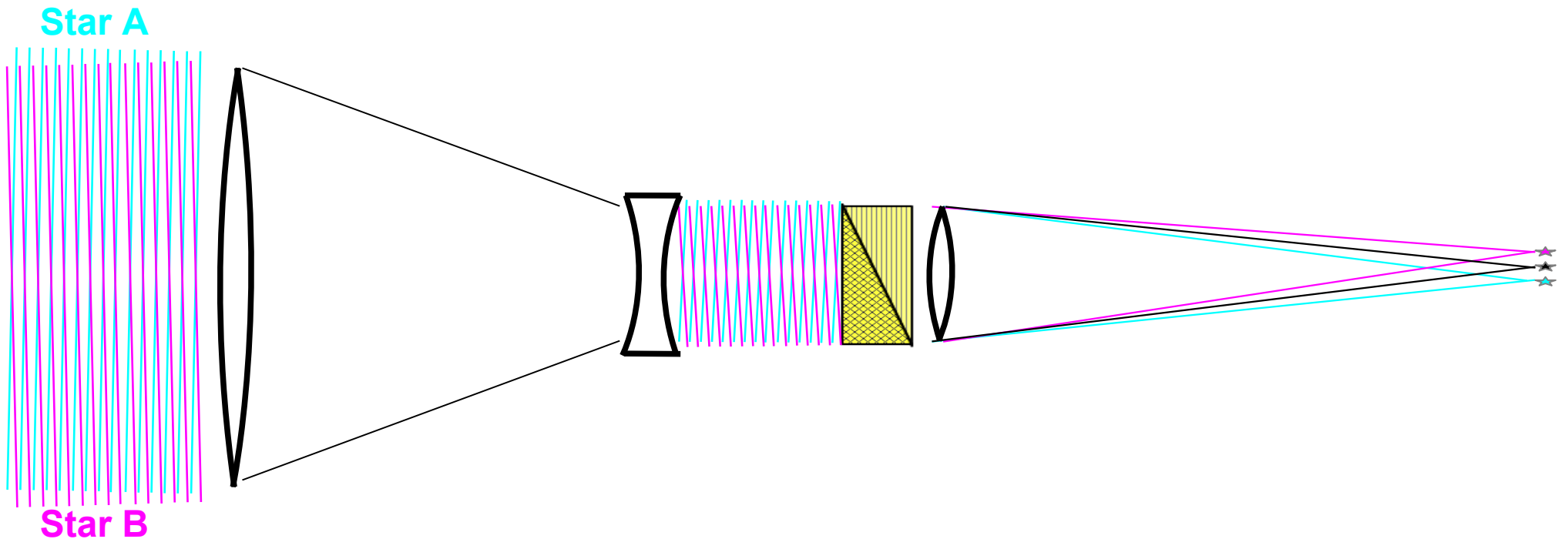

However this still only works for one particular stellar separation angle :-)

Solution to make one that is *adjustable* for different stellar separations:

Replace the fixed afocal telescope by an afocal *zoom lens*

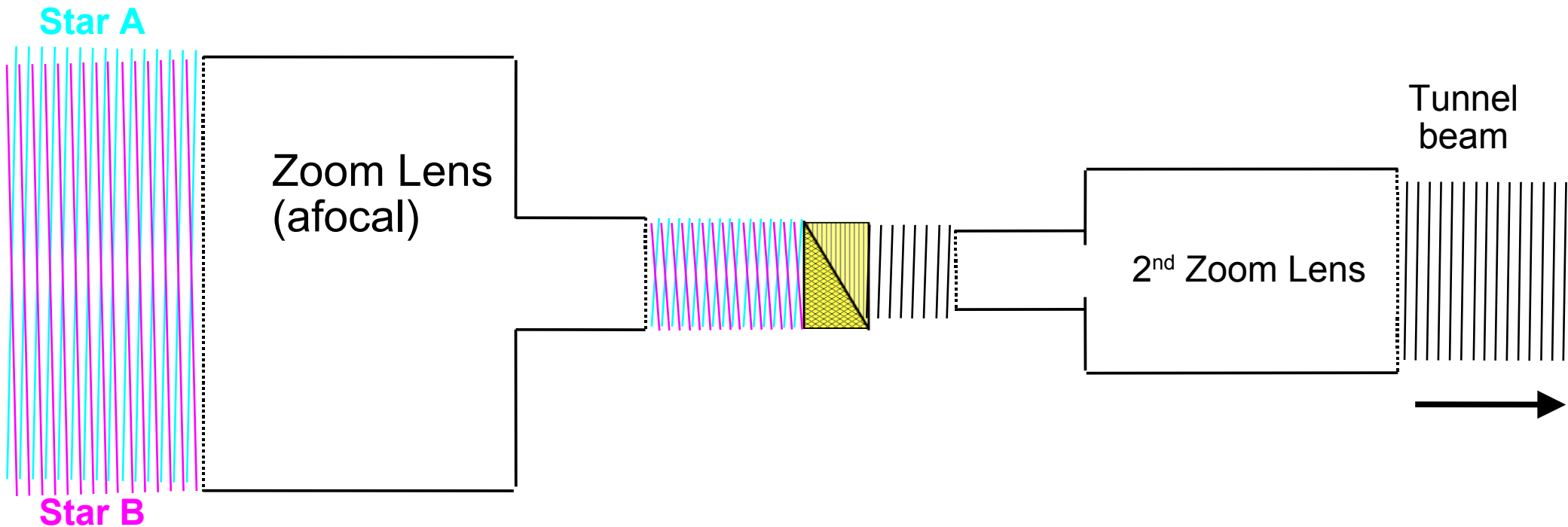

Now this must be followed by a *second* zoom lens which adjusts the beamsize to that required for launching into the relay optics. Also, the zoom lenses may need to take the resulting pupil positions into account.
→ Impractical!

Practical solution: smaller diameter (but with larger α) Wollaston prism in an internal telescope beam (with power) just before (or just after) the telescope focus, at an adjustable position:

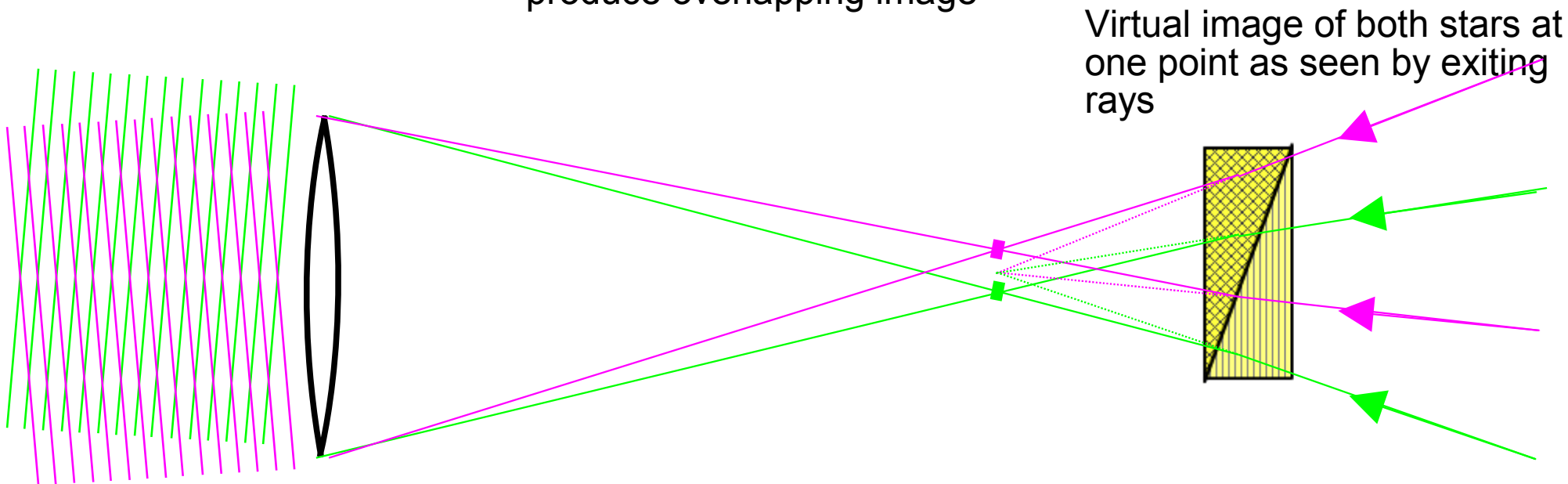
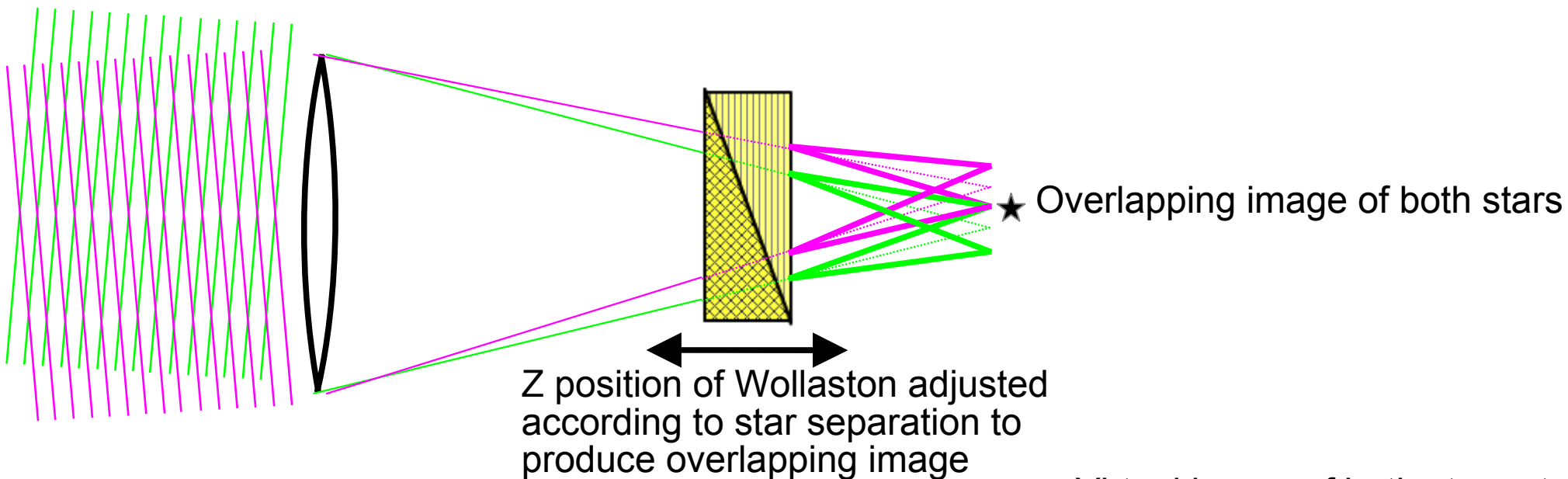

Problem (possibly) with following pupil which is now shifted between the light from the two stars (which now have the same image position)

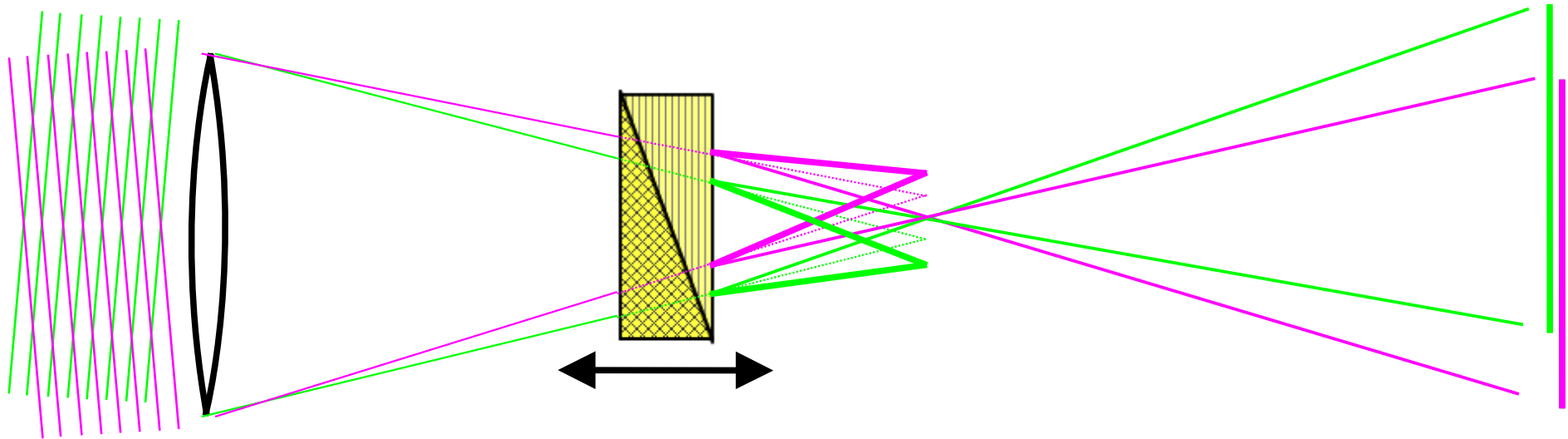

Solutions:

- Transfer the pupil to the position of the Wollaston prism
- Use two Wollastons, one on each side of the focal plane!

Ray tracing to illustrate use of two Wollastons in order to prevent offset of pupils from the lights from the two stars.

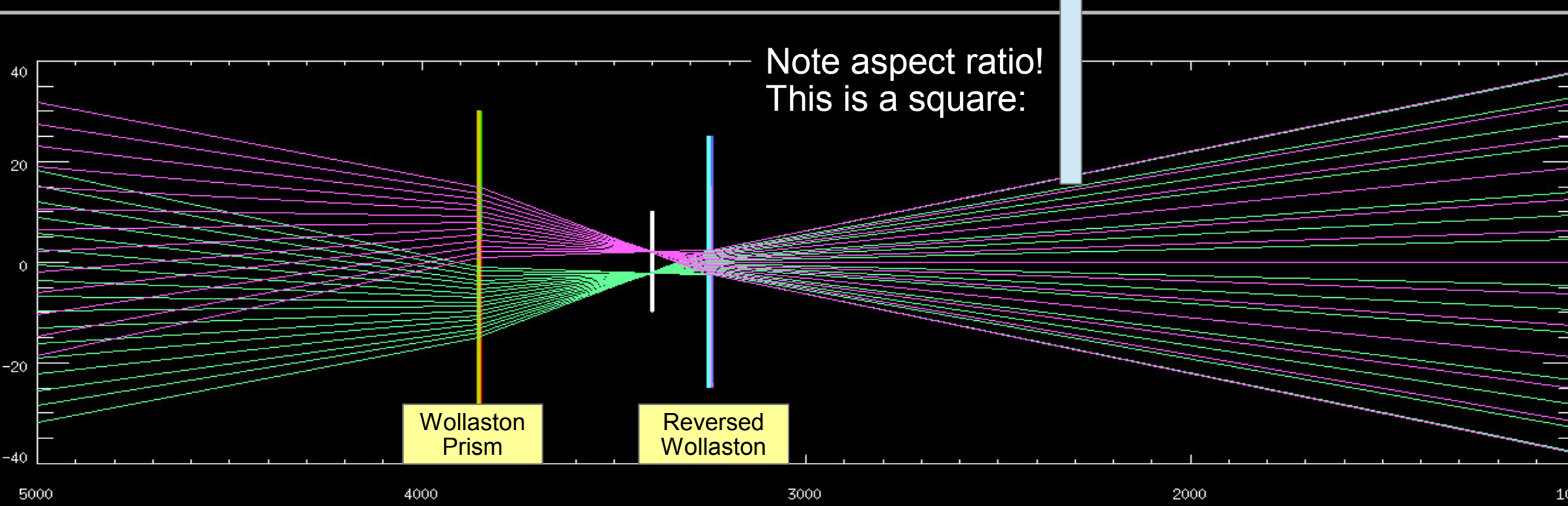
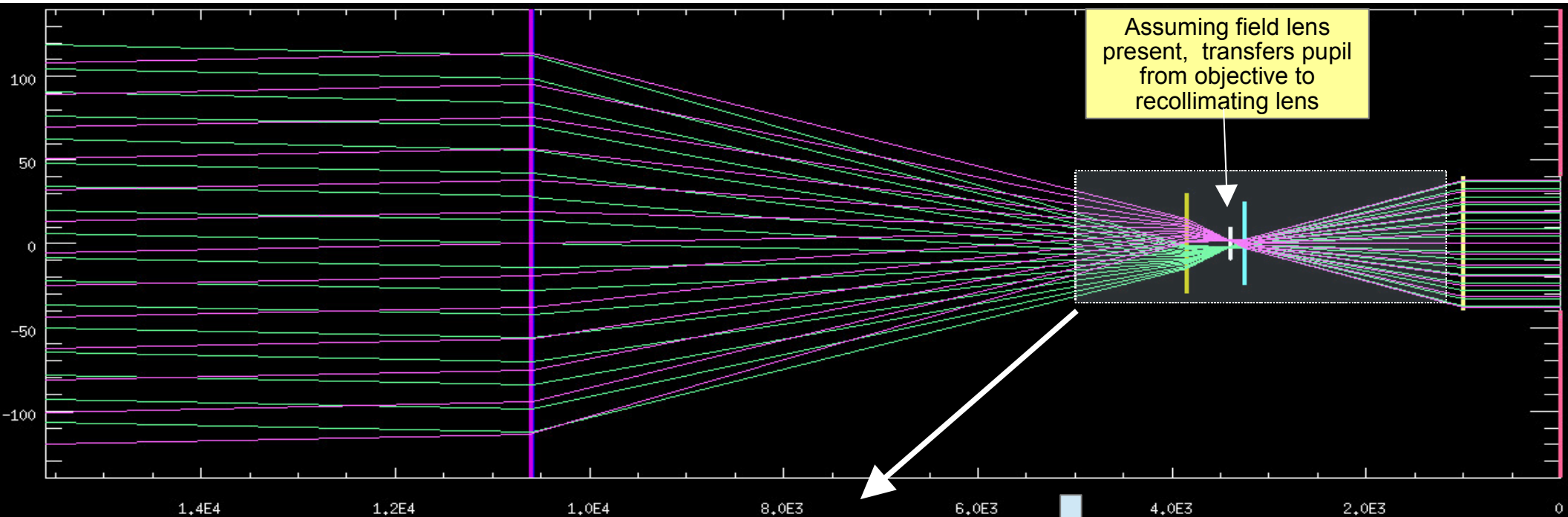

With greater stellar separation, both Wollastons are moved further from the focus, but exit pupils still overlap at right.

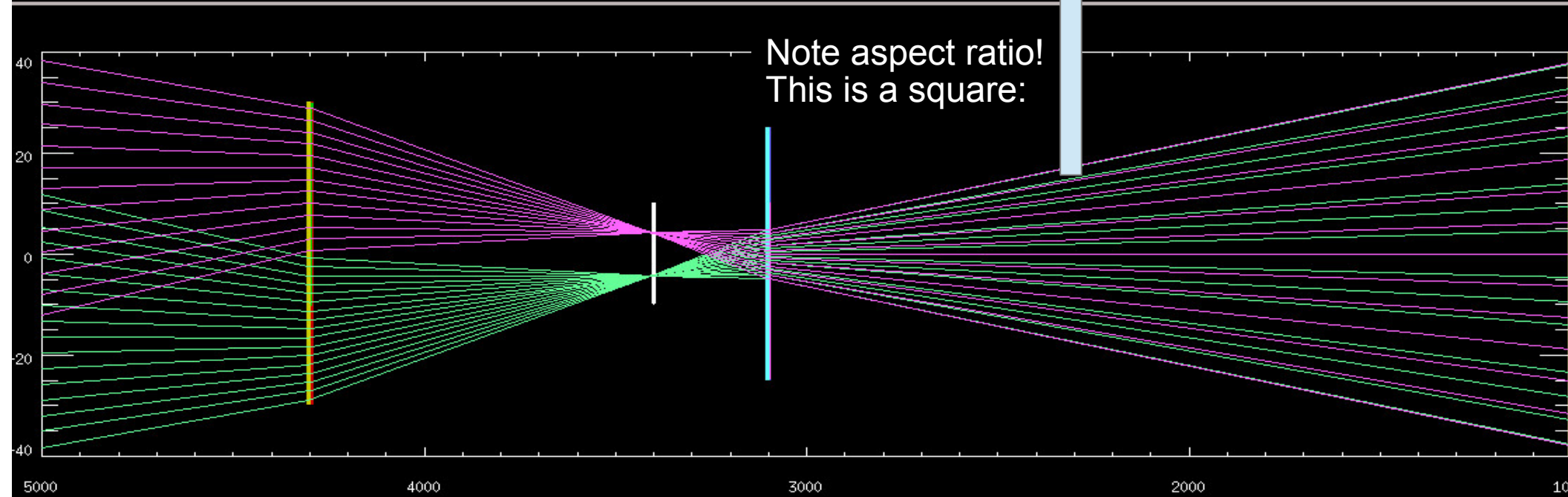
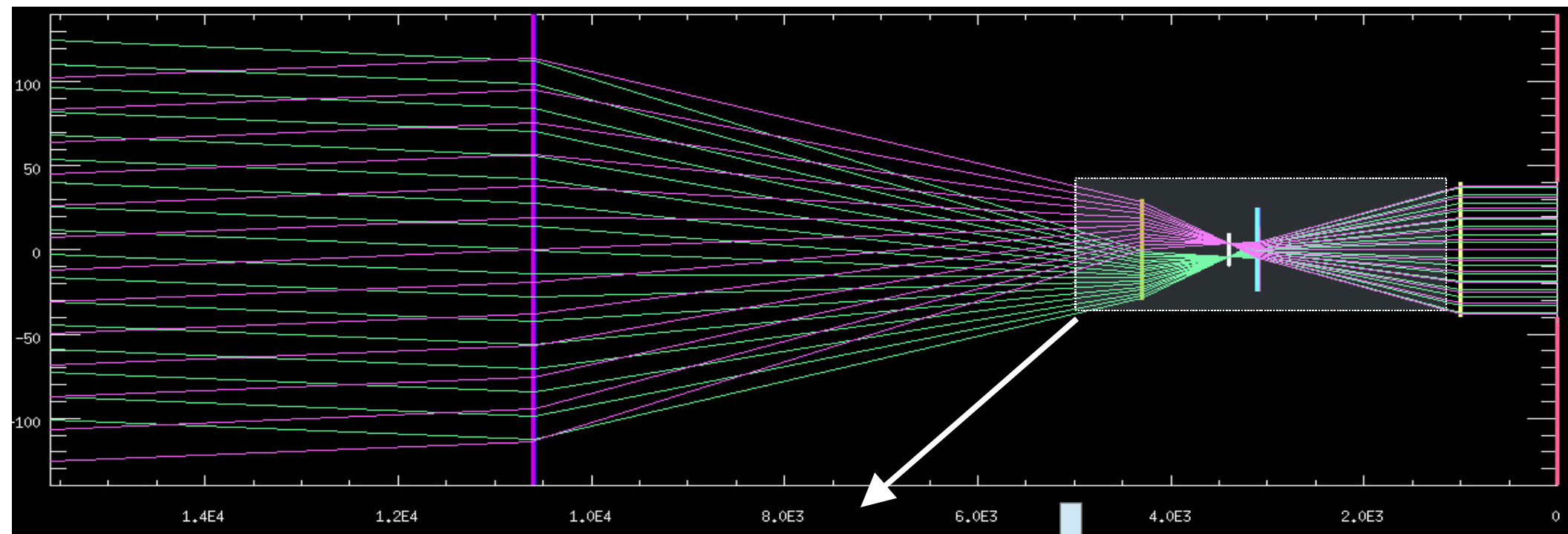

Zero-OPD calibration and commutation strategies for determination of an astrometric result - 1

Zero-point calibration of the DDL position:

- There are ways (such as slightly misadjusting the angle of a half-wave plate used for polarization swapping) to cause some of the bright primary starlight to “leak” into the secondary star channel (identically, in both interferometric arms).
- Then (assuming that the primary starlight is outside the coherence envelope of the secondary star) the secondary channel is adjusted for “zero phase” (whatever the definition of that is, as used during the observation of the secondary). That point becomes the zero-point for the local metrology.
- Then the secondary star is observed in its dedicated channel (with the leakage removed) to determine its OPD position now using the calibrated metrology.
- In order for this to yield an accurate result, the injection of the bright star into the dim channel *must* be performed before non-common mode components affecting the path lengths differently.

Zero-OPD calibration and commutation strategies for determination of an astrometric result - 2

Differencing method for determination of astrometric result:

- Half of the time, the secondary star is observed as delayed with respect to the primary star, and that differential delay line position according to the metrology is recorded.
- Then a commutation is performed so that the secondary star OPD is observed *advanced* with respect to the primary star, with that position again measured using the metrology.
- The astrometric result is one half of the difference between the metrology determination between those two. (Or more practically, the astrometric delay vs. earth rotation curve is fitted around the zero-point consistent with sign reversal of that delay following each commutation).

Zero-OPD calibration and commutation strategies for determination of an astrometric result - 3

Note: Some components shown may be omitted or might not be adjustable

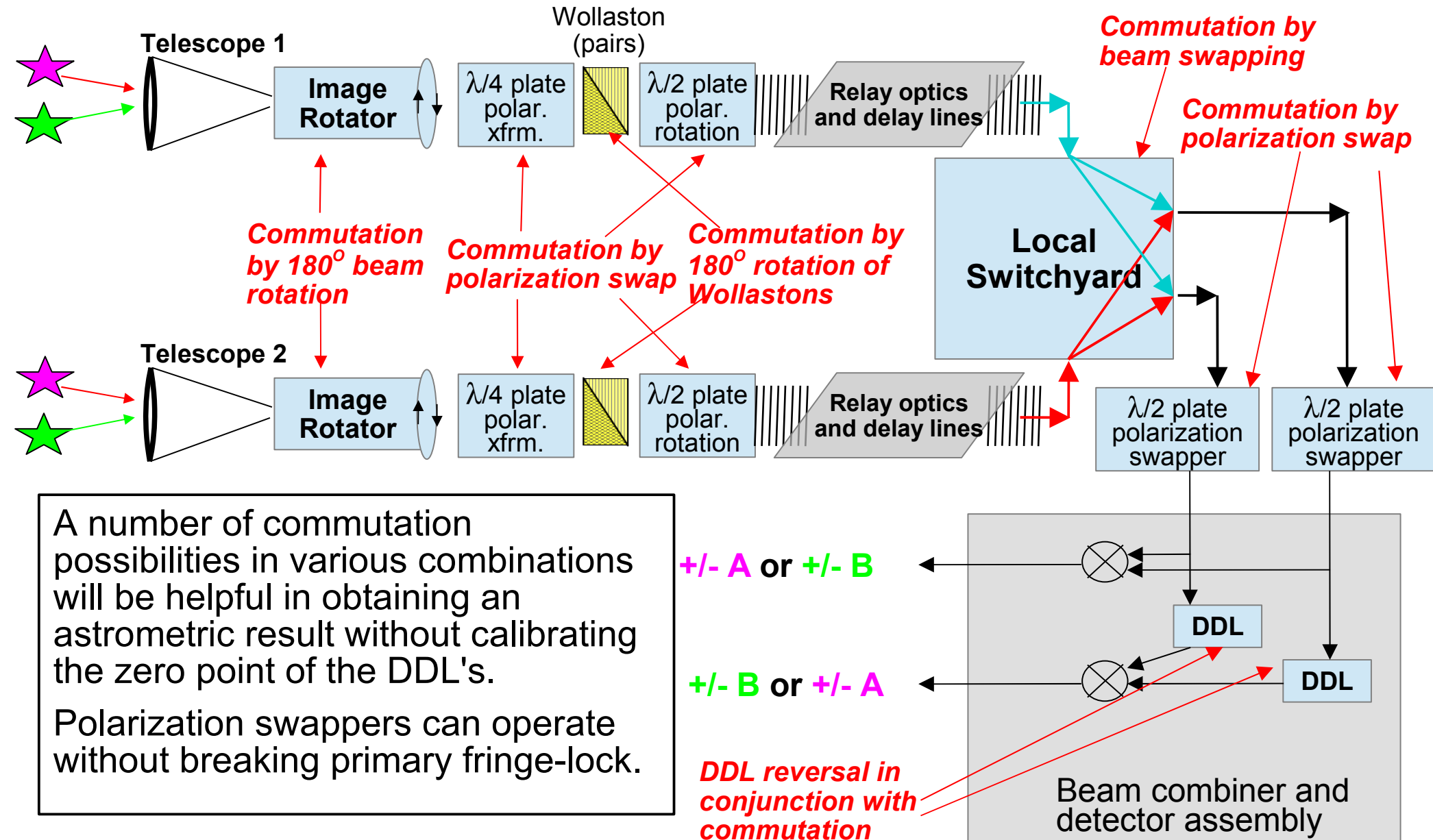

A number of commutation possibilities in various combinations will be helpful in obtaining an astrometric result without calibrating the zero point of the DDL's.

Polarization swappers can operate without breaking primary fringe-lock.

It appears that with the two co-adjusted Wollaston prisms set for an offset between the stars ϕ , the resulting system is equivalent to the original (but very impractical!) idea of a single Wollaston prism at the primary objective having $\alpha = \phi$.

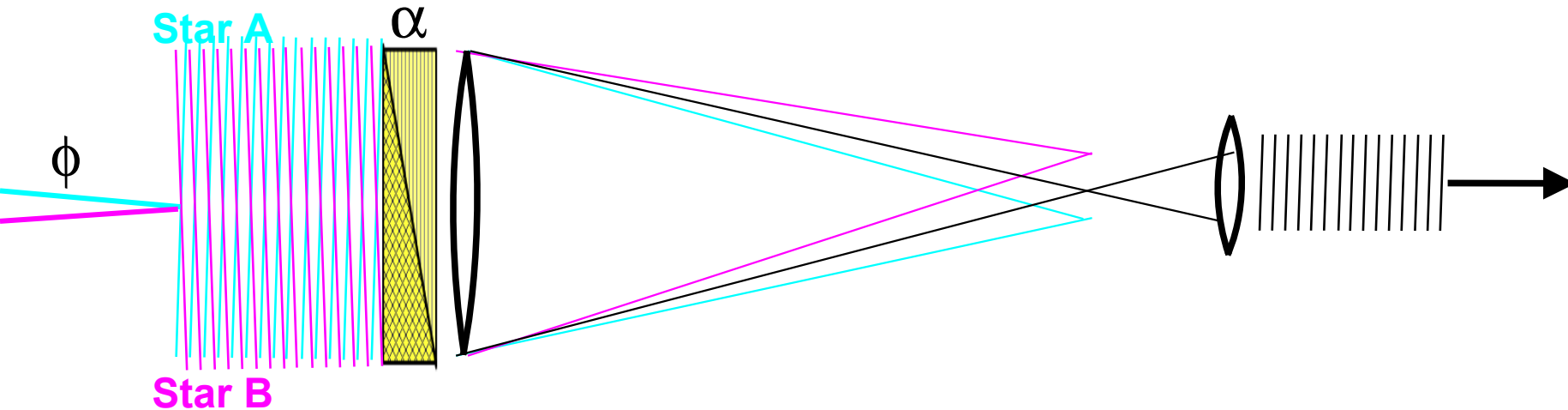

This equivalence is important, because every Wollaston prism has a **zero-delay axis** running across its face (even though this is never marked!) which is critical in defining the astrometric baseline of the resulting astrometric instrument.

The astrometric baseline goes to a point (actually *any* point) on the zero-delay axis of the Wollaston at (or *virtually* at) in front of the telescope.

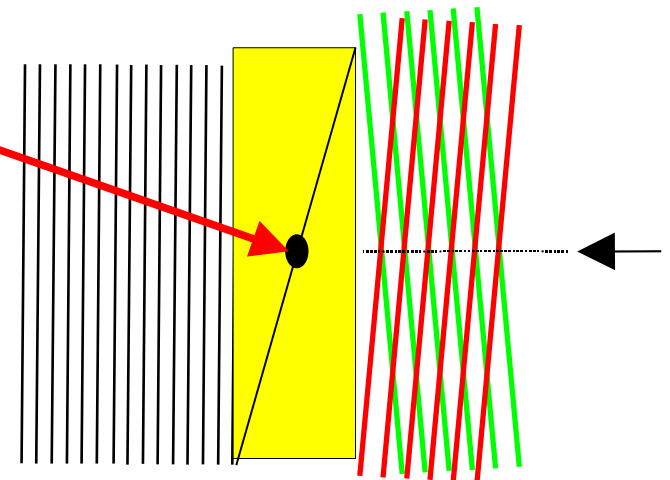

Baseline definition: a critical issue

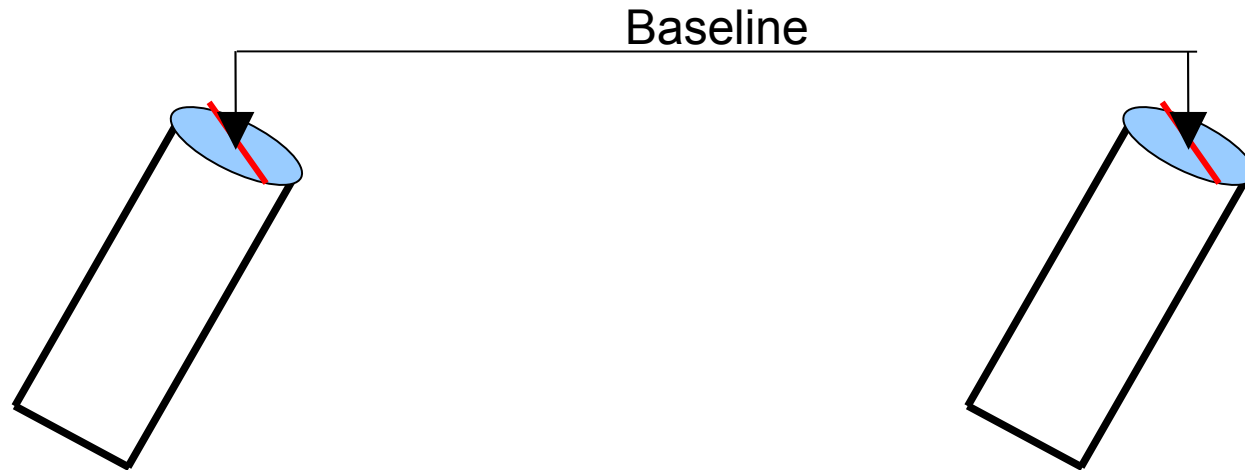

For the purposes of astrometry, the baseline may be defined as a vector between any point on one zero-delay axis of one Wollaston and the zero-delay axis of the other Wollaston (for all these choices, $\Delta\text{OPD} = B \cdot \alpha$ will be the same).

You can also take any point going from one such point at an arbitrary distance in the direction of the central boresight (the direction halfway in between the two stars).

However, to define a point for the baseline which is fixed when the Wollaston (virtually) rotates, then it should be a point on the zero-delay axis which the axis rotates about.

Baseline definition positions, looking into the telescope primary. In order to have a fixed reference point for the baseline, the axis of rotation must be on the zero-delay axis of the Wollaston:

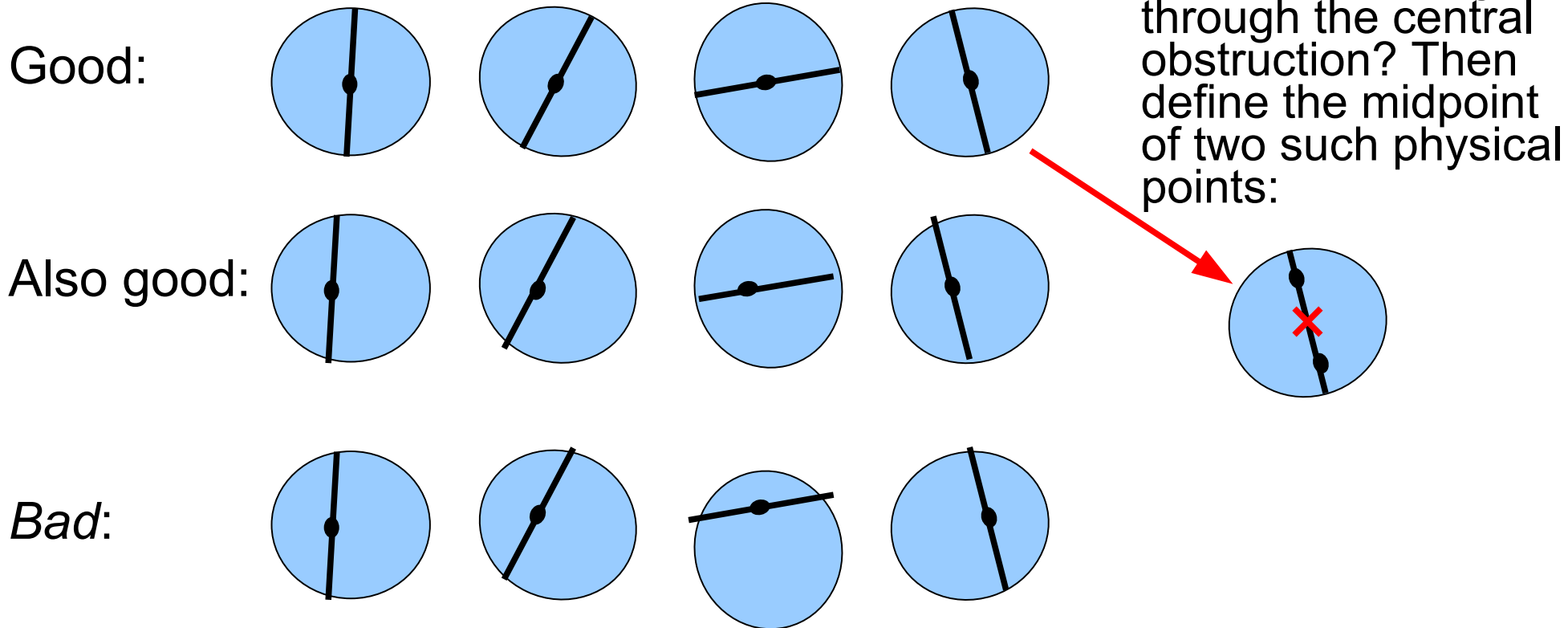

However having a reference point for the baseline which is fixed at the telescope isn't necessary, only the ability to track *during an observation* a applicable baseline vector which properly relates the (unknown) stellar separation vector to the measured OPD offset.

So the baseline doesn't just need to be defined, it needs to be *known*! Attaining the astrometric precision expected for PRIMA requires knowledge of the baseline component in the direction of the separation vector – with the separation vector being an unknown -- or “*the*” baseline, if referenced to a fixed position on each telescope, with an accuracy of .05mm.

It cannot be assumed that a point defined on each telescope, even if the telescopes are “identical”, will maintain a separation vector constant to .05mm!

A baseline metrology system which can operate at regular intervals (or continually) during an observation is thus almost surely required to meet the above goal.....

Baseline metrology systems:

- A coherent (interferometric) referencing beacon will determine an astrometric baseline which can also be used with a PRIMA type (metrology-based) dual-beam system. (not shown). This is a *one-way* metrology solution not unlike that of GRAVITY, but with the light going *toward* the beam combiners.
- A local referencing beacon (need not be coherent) can be employed at each telescope using the proposed polarization-multiplexed system, one telescope at a time.

In either case, the vector between the reference points must be measured using (absolute) distance metrology of some sort. (This would be the sort of metrology used at NPOI to ascertain the position of their baseline reference points with respect to ground coordinates.)

Baseline metrology system for the proposed telescopes:

Local referencing system fixes the position of a baseline reference point (as previously defined) at each telescope, independently.

Concept:

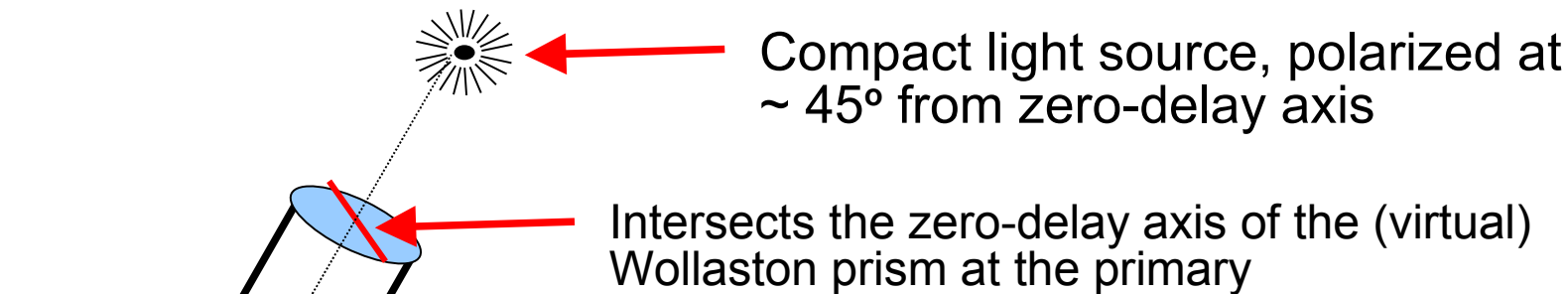

Principle of operation:

When viewed further down the optical train (including at the interferometric beam combiners) in the direction in between the two stars (or a slightly different specified direction, but identical for all telescopes) the beacon light will only still be linearly polarized at (about) 45° when it is actually positioned on the baseline reference plane (or the baseline reference line, if that remains true as the Wollaston axis is rotated).

Baseline metrology system for the proposed telescopes:

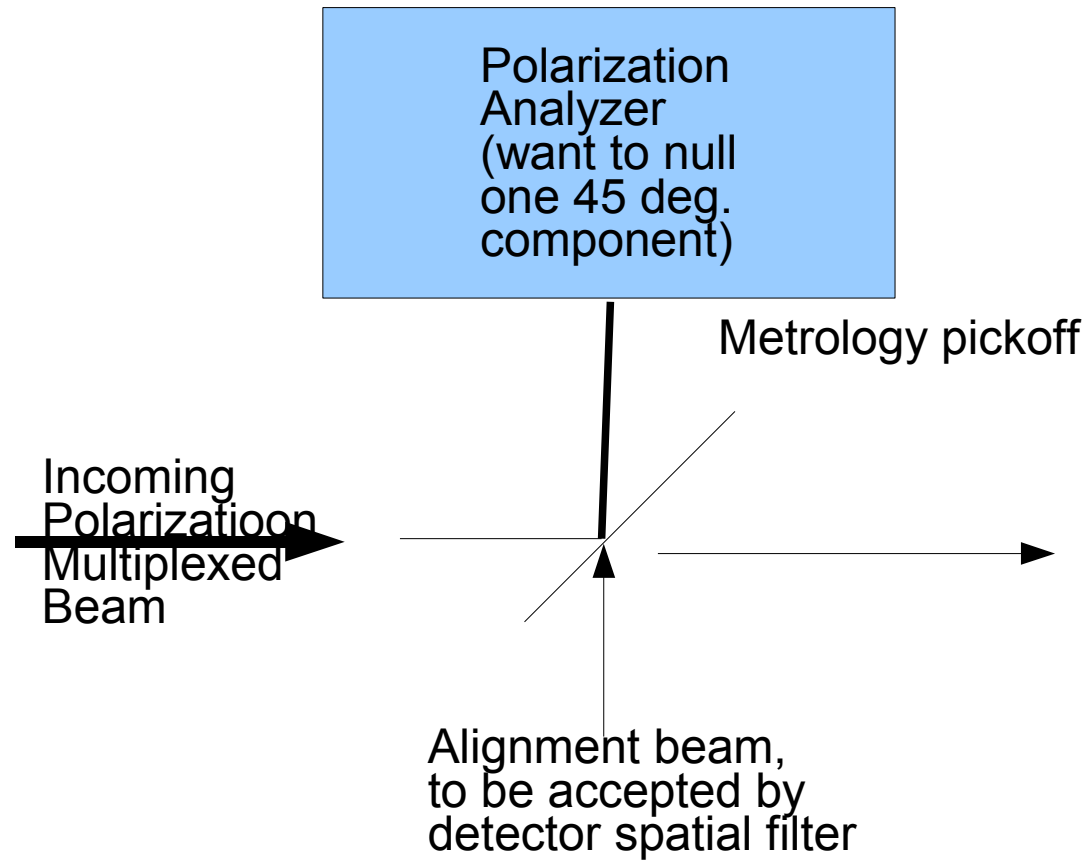

Polarization rotators using nearly achromatic halfwave retarder.
 Example of broadband (NIR) half-wave retarder using a double-rhomb
 (4 TIR reflections) in a low-dispersion glass

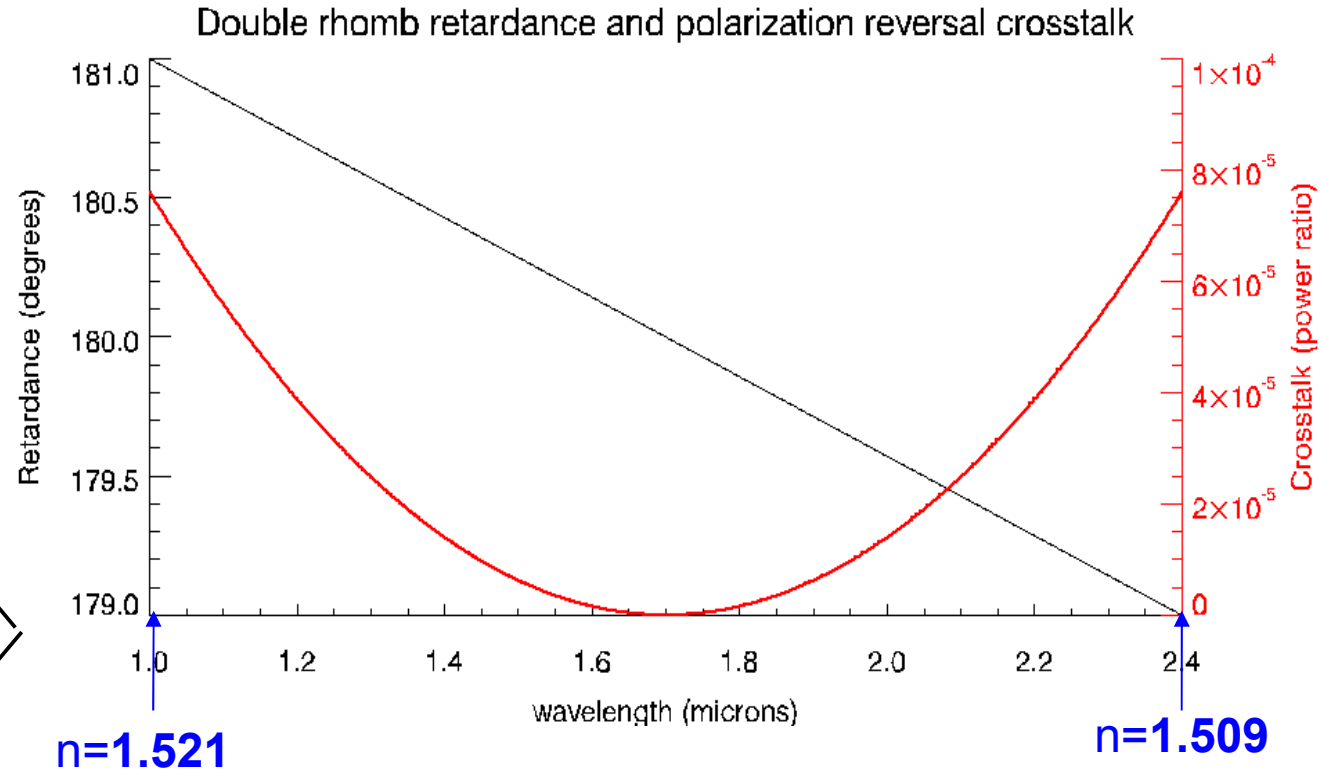
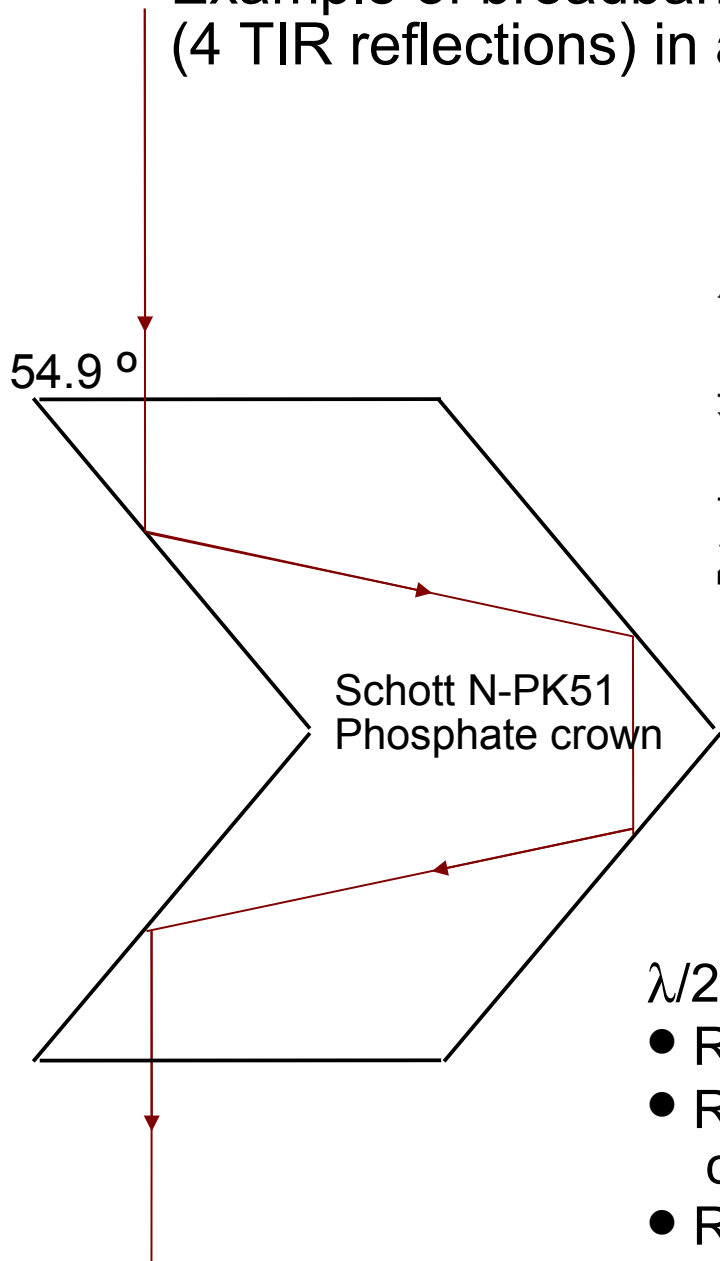

- $\lambda/2$ Retarder used for switching linear polarizations:
- Retarder at 0° : No polarization reversal, no crosstalk
 - Retarder at 45° : Polarizations reversed, crosstalk $< .0001$ over wavelength
 - Retarder at θ : Polarizations rotated by 2θ (temporary)

WRITE HERE!

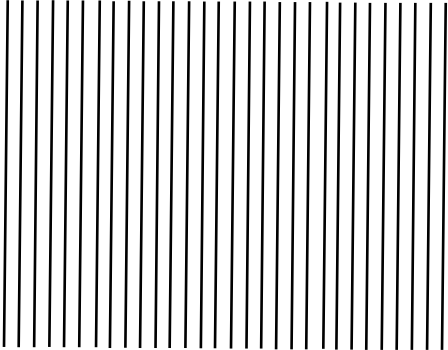
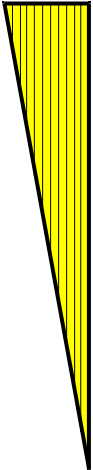
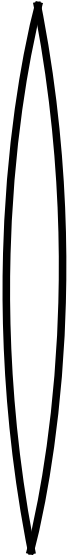

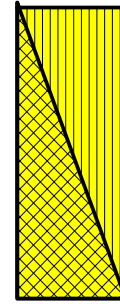

OLD VERSION: Zero-OPD calibration and commutation strategies for determination of an astrometric result - 3

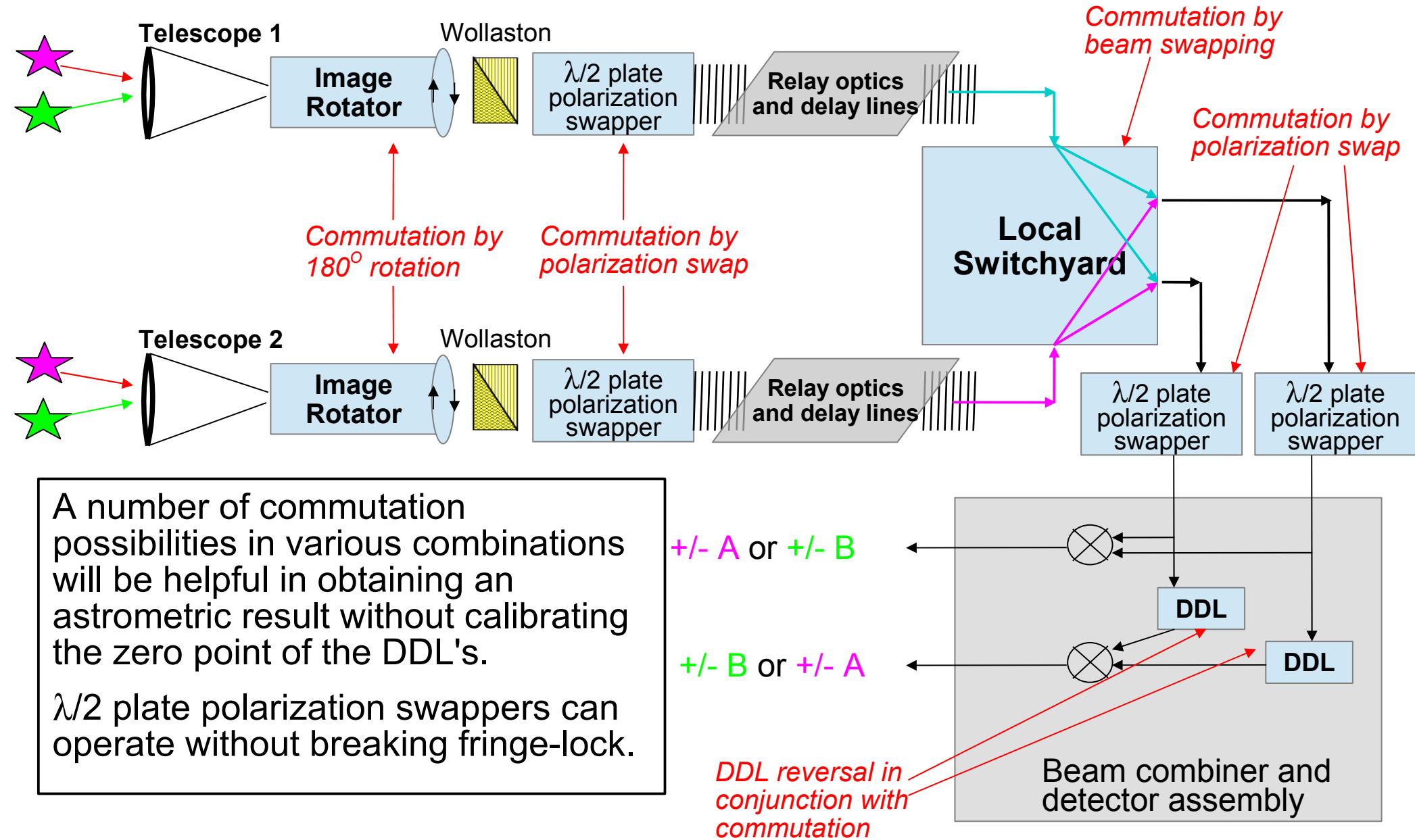

A number of commutation possibilities in various combinations will be helpful in obtaining an astrometric result without calibrating the zero point of the DDL's.

$\lambda/2$ plate polarization swappers can operate without breaking fringe-lock.

Backend: can use the NFT detector
concept....

modified.

